



# Intelligence for distribution systems

Automation concepts

## Effects of the energy revolution on the distribution system

The distributed feed-in of renewable energies has changed conditions in the supply networks. The widespread feeding in of power from photovoltaic, wind and biogas plants is making it more and more complicated to ensure stable power systems with reliable voltage and frequency bands. In the high and medium voltage (HV/MV) transmission networks, bottleneck management and transformer tap control, for example, provide necessary mechanisms for adjustment. But the effects of distributed suppliers are considerable precisely in the distribution networks, because the meshed, usually heterogeneous structures typically lack regulation algorithms and control variables such as adjustable transformers. The cables, overhead lines and their switchgear have not been planned or designed for these new energy flows. So the network equipment can come under great loads, which reduce its service life. Without additional sensor systems and data collection, these states remain largely unknown. The resulting costs caused by premature replacement of equipment and reduced remuneration for power system use owing to longer downtimes can be considerable. In addition to the obligation for voltage stability, power system remuneration is coupled to the power system quality provided using the Q factor under the German Ordinance on Incentive Regulation. An improvement in availability and shortening of outage times would be in the economic interests of the supply companies for this reason alone.

## Distributed intelligence is the solution

Rapid expansion of the power systems is hardly possible and furthermore extremely cost-intensive. Intelligent networks are a suitable solution, as the expansion can be carried out selectively and at an appropriate time. About 500,000 transformer stations are currently in use in Germany in the form of connection, client or local network stations. Experts estimate that approximately 10-15% of these sta-

tions would have to be incorporated into an intelligent network to achieve significant controllability. Due to the large quantities, this requires considerable effort and expenditure and must be well planned since the additional information from the networks often reaches control systems which are already at their capacity limits with the integration of the distributed suppliers. A suitable technological and economical telecontrol solution must therefore:

- Be able to accurately pre-select and process information from the different measurement systems for the control centre;
- take into account the space conditions depending on the type of station (compact station or accessible station) and in case of doubt, the dimensions must be suitably compact;
- be quick and easy to integrate into the existing structures in order to reduce the total expenditure.

The stations should be categorised into different classes as regards their varying significance in safeguarding network stability:

- 1 Stations with telemonitoring without remote control
- 2 Stations with telemonitoring & remote control
- 3 Stations with telemonitoring, remote control & protection

These problems posed must also be solved for existing as well as new systems.

## 1 Stations with telemonitoring without remote control

The simplest form of monitoring for transformer stations is the incorporation of earth fault and short circuit indicators. The units help to localise faults in the network reliably. In the case of distributed generation and the resulting bidirectional power flow, the use of units with additional direction display is recommended.

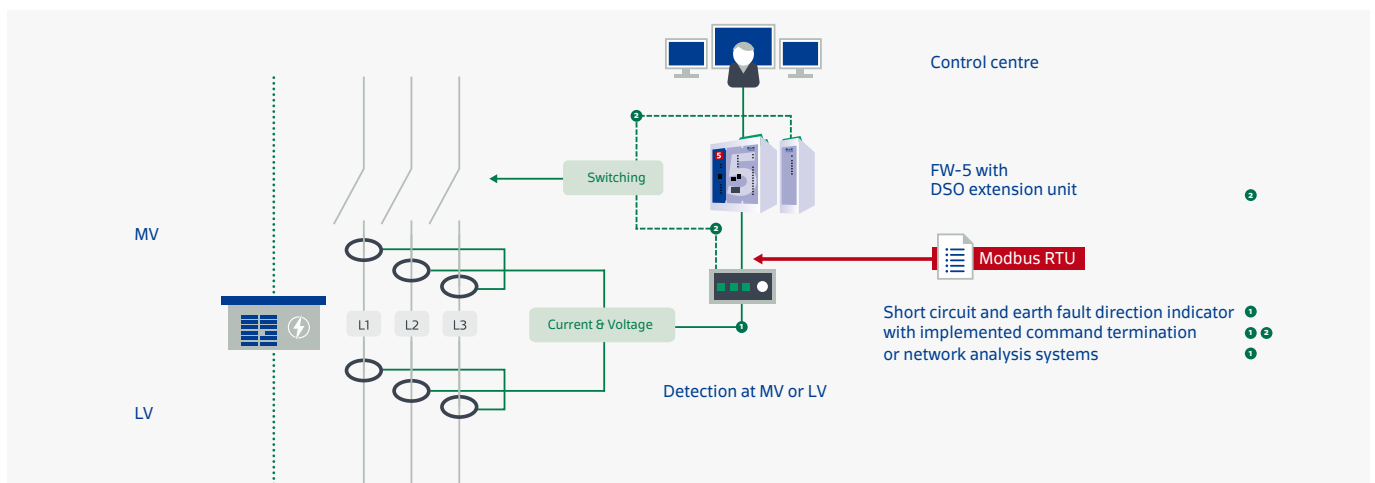

Measurement with short circuit and earth fault direction indicators or network analysis systems; different switching options.

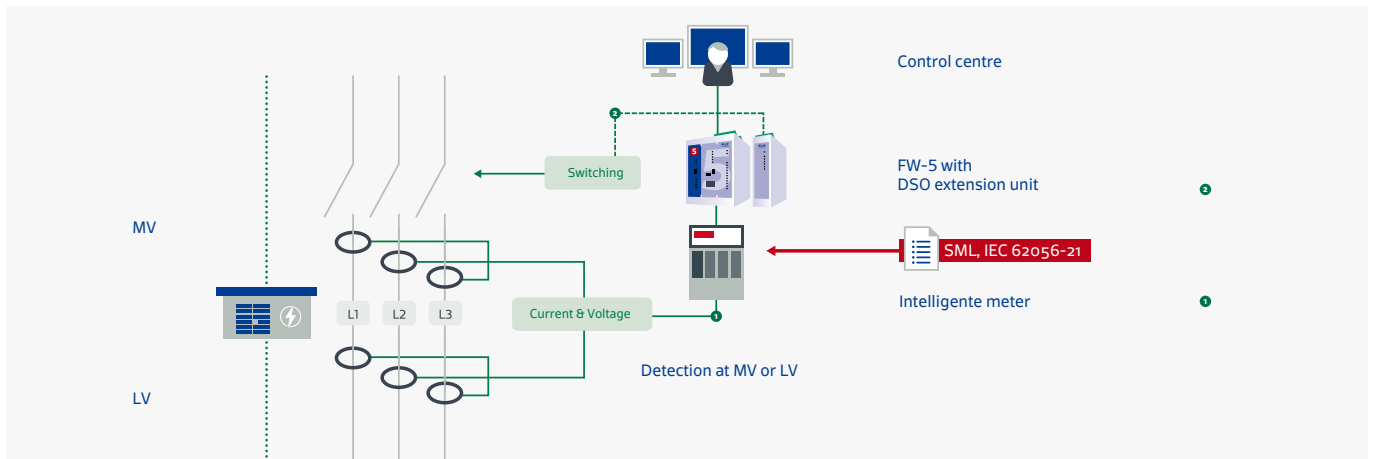

Connection to intelligent meters. Optional switching via DSO expansion module.

## Network monitoring

Different systems are available for widespread network monitoring, which also provide network figures in addition to simply fault detection, such as for example:

### Load current monitor

- Detection of phase currents  $L_1$ ,  $L_2$ ,  $L_3$
- Average values of the last 15 minutes
- Non-return pointer function
- Detection of unbalance current  $I_E$

### Voltage monitor

- Detection of phase voltages  $U_{LL}$
- Displacement voltage  $U_{NE}$

### Monitoring of other power system characteristic values:

- $P$ ,  $Q$ ,  $S$ ,  $\cos \varphi$ ,  $f$

### Detection of power flow direction:

- Forwards/backwards, A/B

## Technical realisation

There are different approaches:

- Pick-off of currents and voltages on the MV side
- Pick-off of currents and voltages on the LV side

In new network stations, an intelligent short circuit and earth fault direction indicator is usually already installed ex-factory. Readings can be taken and values derived by the voltage information and split-core current transformers or sensors. The retrofitting of taps on the medium voltage side is complex on existing network stations. Measurements can be taken far more easily on the low voltage side. Based on the values measured, the telecontrol system can then calculate the medium voltage value. This task can be solved very easily and conveniently using the calculation value function which is integrated in the configuration tool setIT, since no PLC programming is required. Actuating variables such as primary and secondary transformer voltages can be entered into the station as variables from the web server, setIT or the control centre.

Four-quadrant meters are built into connection stations in particular in part. These also provide the meter reading and

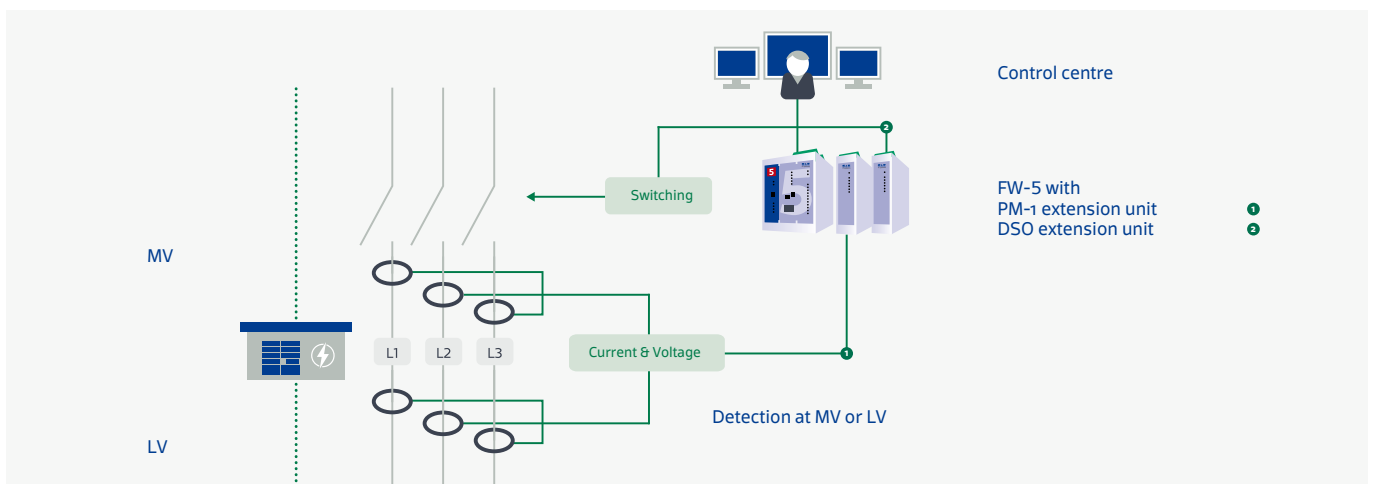

Everything from a single source PM-1 for measurements, DSO expansion module for secure switching.

all required parameters over a serial interface. The SML protocol of the Sym<sup>2</sup> meter or IEC 62056-21 (formerly IEC 1107) is provided as the protocol. The values are sent in the OBIS data model and are predefined in setIT.

In addition to the reading of values via external systems, an output measuring module is now available as an expansion module for the net-line FW-5 and FW-5-GATE. The PM-1 module has four current and three voltage inputs and calculates the derivable values. It is therefore a space-saving and low-cost alternative to external measurement devices and network analysis systems.

As it is not practical to transmit all the data provided by the measurement systems to the control centre as well, a selection and optimisation of the relevant data (e.g. by the hysteresis for measured values) can be carried out in the

### Combined know-how

We were already able to establish links to numerous systems available on the market, e.g.:

- Horstmann ComPass B, B<sub>n</sub>, B<sub>s</sub>, B<sub>p</sub>
- Kries IKI 50 Grid Inspector
- A.Eberle EOR 3D, NRG 96, ESM NA 400, ESM ENA 7000
- Janitza UMG 103, 104, 604, 96

Templates for automatic adaptation of relevant capacities are created in our setIT configuration software for the most popular systems. Modbus RTU is used for coupling between the measurement systems and the telecontrol system.

telecontrol station. Processes can also be logged here in freely selectable measurement periods. These can then be transmitted directly to the control centre or read out on site for evaluation at a later stage. For all types of station with telemonitoring, the compact net-line FW-5 compact system is recommended which comes in different basic forms and with expansion capabilities.

The telecontrol station and all interposed telecontrol interfaces manage the values of the connected components in the process image. All the information from the measurement points can be read out and displayed in diagnostics using the setIT configuration software or the web server and stored for more precise evaluations in the station archive.

## 2 Stations with monitoring and remote control

In local network stations with remote control, a DSO module (DSO = Distribution System Operator) is also required as an addition for the FW-5 system. The DSO-1 or DSO-2 modules allow secure command termination in networks by means of:

- 1/n monitoring
- Measuring circuit test and runtime monitoring
- Optional cascading for command groups

The command relays are 1.5- or 2-pole and managed by means of release relays. Activation can take place in single or double commands. This assures the secure control of servomotors, whereby faulty network segments can be quickly removed from the network and the availability of intact sections can be swiftly restored. Even some of the aforementioned short circuit and earth fault direction indicators and network analysis systems have already implemented the command termination options.

### Excursus - Wide range control

In addition to the option to activate faulty network segments, some system operators use the collected measured values for an initial form of automated load optimisation. Since the local network transformers are not usually adjustable, the overall balance of a network segment is considered and the corresponding provisions are taken on the superimposed UW. Significant efficiency improvements can already be achieved in practice with this global control option.

### Recommendation in regard to UPS

It is useful to equip stations at central positions in the network with uninterruptable power supplies which, in the event of a power cut, still allow interventions for a certain period of time, such as for example:

- Notification of network errors
- Targeted switching
- Defined "reboot"

Due to the high starting currents of the switching devices, the battery power must be sufficiently powerful in order to be able to perform the desired number of switching operations. Depending on the geographical location and design of the station (compact, accessible, etc.), the system may reach extremely high temperatures which can have a negative effect on the service life of the batteries. It may therefore be useful to equip the system with air-conditioning and/or switchgear cabinet heating to assure the safe operation of the battery.

### 3 Stations with monitoring, remote control and protection

The most comprehensive form of automation is found in the use of protective equipment in local network stations. In addition to the functionalities of the aforementioned systems, these also provide the autonomous protection of equipment. We can recommend our very own SG-50 combination protective equipment for protection. The SG-50 is available in different variants: With four current inputs for simple IOC protection, and with additional voltage inputs for more advanced functions. The protection functions of the system can (even subsequently) be configured from the well-structured software.

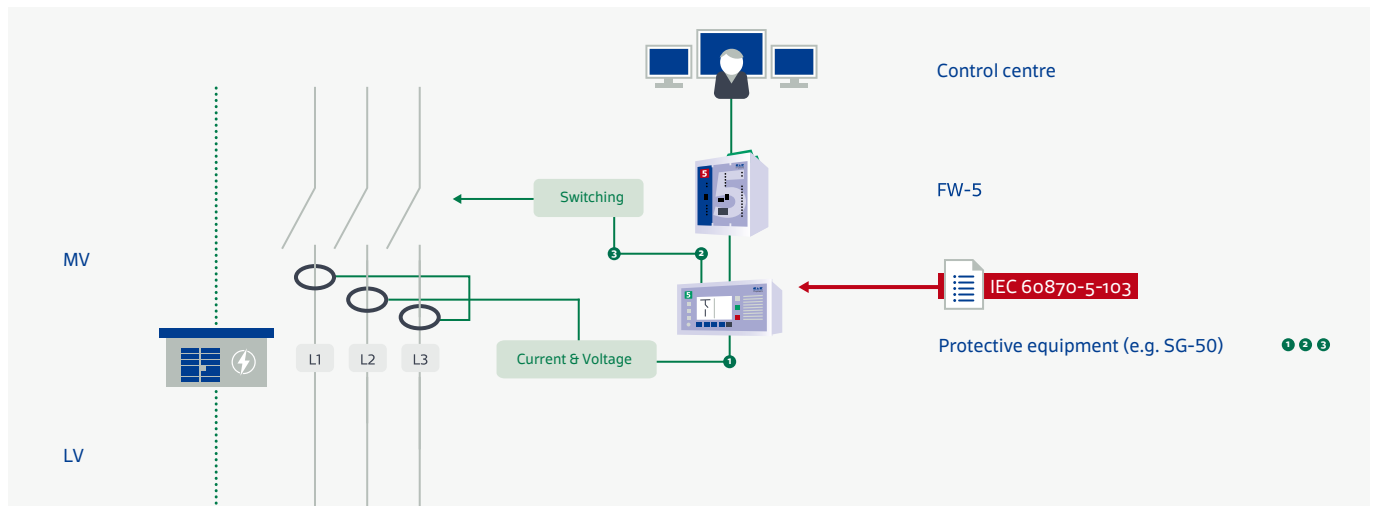

Measuring, switching, protecting – using the SG-50 combination protective equipment.

#### General information about the solutions

##### Housing

The aforementioned components are typically mounted in a wall enclosure. The telecontrol system, the transmission modem, the uninterruptible power supply and the transfer terminal are housed in the switchgear cabinet. To prevent heat building up in the summer, the dimensions of the housing should not be chosen too small. If no separate room is available in the local network station for the secondary technology, one clever solution is to use magnets to attach the switchgear cabinet.

##### Data transmission paths

If no separate transmission routes are available to the local network stations, the transmission is completed more and more frequently via DSL/GPRS/UMTS/LTE; as a rule via TCP/IP-based transmission routes with the IEC 870-5-104 protocol. The requirements made of protection against unauthorised access when these communication paths are used are justifiably very strict! Depending on the present infrastructure, it is advisable to use the following safety features with regard to BDEW-Whitepaper and ISMS:

- User administration
- Certificates (for https and ftps)
- Secure protocols
- End-to-End VPN encryption
  - IPsec
  - OpenVPN
- Firewalls

SAE's own M2G-1 is of interest for data transmission over GPRS. The modem is configured with setIT and the connection set-up phases can be analysed accurately with the diagnostics capabilities of the latest setIT generation.





### Wide range control solution

In the Rittal plastic housing with Phoenix Contact power supply and FW-5-GATE in the 24-Volt variant. M2G-1 GPRS modem for secure data transmission with IPsec VPN encryption and hardware-based decoupling via the serial V24 interface.

The measurement is realised by a Janitza UMG-103. To ensure a straightforward connection, terminal strips already labelled are provided in the bottom part of the box.

#### Special feature:

The SAE GPRS modem M2G-1 ensure the straightforward communication configuration in setIT. No additional configuration software is therefore required.

The Reset button can be used to locally switch the modem and station to volt-free, thereby forcing a restart; e.g. to re-establish the GPRS connection.

For a quick and straightforward installation, the box is attached to the side of the switching station using magnets.



### Extended intervention option

In the Rittal metal switchgear cabinet with FW-5, the Dr. Neuhaus Tainy EMOD modem, the Phoenix Contact UPS and a 12-Ah battery (also by Phoenix Contact).

#### Special feature:

The combination of UPS and the powerful battery allows switching operations to be performed within a certain timeframe after or during a possible error.



### Monitoring and switching

In the compact metal switchgear cabinet by Rittal with FW-5-GATE-230, output measuring module PM-1, DSO-1 for secure switching, Lucom modem for data transmission and transfer terminal strips in the bottom part of the box.

#### Special feature:

The 230-Volt variant of the FW-5-GATE provides the power supply of the modem and communication modules, so that no separate 230V-AC power supply is required.

#### Recommendations and options

For stations without remote control, an uninterruptible power supply can be implemented simply and cost-effectively with the 230V-AC variant of the FW-5 system. The battery is connected directly to the FW-5, and charging circuit and 24V-DC for modem and signal voltage are supplied by the FW-5.

The remote I/O (TBUS-T & TBUS-R) is used to connect separated expansion modules. This provides the option to control several faults via one box.



## Even special requirements are possible

The net-line FWG-50 has been designed according to the requirements of one of our clients, specifically for the automation of 10 kV plants. The telecontrol unit is composed of standard components of the series5 or series5+ series of products. A special feature of this system is its accommodation in a metal housing as a rack drawer. Its 8.8 cm height and 60 cm depth has been adapted to restricted space conditions in 10 kV plants and allows the unit to be accommodated inside the plant.

In addition to the telecontrol unit, the housing also has space for a communication component such as a TETRA radio modem, DSL modem, VFT dedicated line modem or another type of interface. Local earth fault/short circuit direction indicators or protective equipment can be incorporated via an RS-485 interface.

All the supply and communication connections necessary for operation lead out of the front.

The required status information is displayed on the front panel using LEDs. Process integration takes place by means of a Harting connector attached to the side.

The telecontrol unit communicates with higher level devices by means of the standardised telecontrol protocols IEC 60870-5-101 or -104.

The FWG-50 also has the following functions:

- Detection of faults in the medium voltage station and UPS
- Teleswitching of 3 load interrupter switches by 1.5-pole double commands
- 1/n command termination with switch position check-back signal by means of double-point information
- Detection of short circuit indicators of the 3 outgoing circuits
- Resetting of short circuit indicators
- Two measured values e.g. for transformer temperature
- Standardised terminals for flexible replacement



## Additional components

If the system voltage fails, an uninterruptible power supply (UPS) manufactured by Schneider supplies auxiliary power for a certain period. This capacitive 24V-DC UPS is used in the same housing shape in the rack to the left of the telecontrol unit. The load interrupter switches are teleswitched via DSO modules with 1/n monitoring (counterpart to DSO cards) by the servo-motors of the switching station.



SAE IT-systems GmbH & Co. KG  
Im Gewerbegebiet Pesch 14  
50767 Köln (Cologne, Germany)  
Phone: +49(0)221/59808-0  
Fax: +49(0)221/59808-60  
info@sae-it.de  
www.sae-it.de