



net-line FW-5-GATE-4G with built-in LTE modem



Safe connection

The comprehensive monitoring and control of supply networks and other large infrastructures is not economically viable without a mobile radio connection. The net-line FW-5-GATE-4G brings together powerful telecontrol technology based on the latest series5e generation of CPUs with an LTE modem for flexible mobile radio connection.

As with all FW-5 series remote terminal units, the FW-5-GATE-4G can be extended with I/O extension boards and interface modules in top-hat assembly. This makes it easy to implement compact telecontrol systems with the exact required capacity.

The FW-5-GATE-4G allows for a high degree of IT security in harmony with the requirements of the BDEW whitepaper and BSI recommendations.

Typical application areas

- Intelligent local network stations with integration of power measurement terminals, earth fault-/short circuit indicators, network analysis systems and protective equipment
- Feed-in management in renewable energy plants
- Control box for direct marketing and balancing energy
- Intelligent measurement point for wide range regulation in distribution networks
- Monitoring of media and infrastructure systems in pipelines
- Controls for street lighting
- Merging virtual power stations using VHPready

FW-5-GATE-4G overview

Compact bay station controller with integrated LTE mobile radio module in a synthetic housing suitable for top-hat rail installation. LTE/4G with 3G/2G fallback for high availability. 2x independent Ethernet LAN 10/100 BaseTx, 2xRS-485 field and meter interfaces, RS-232/V.24.

Integration with IEC 61850, DNP3, IEC 60870-5-101/-104, -103 protection device link, Modbus, DSfG. Meter connection IEC 62056-21, SML or S0 pulse.

End-to-end VPN Tunnel (IPsec/OpenVPN) from the station. PLC programming to IEC 61131-3 optional. Configuration via LAN, USB, memory stick or micro SD card. 24 V DC supply. Extension up for 12 I/O modules.

Hardware

The FW-5-GATE-4G is based on the series5e CPU generation. Thanks to a processor speed of 1200 MIPS it has enough power; also with respect to future challenges. The improved performance in particular has a positive impact on network communication via IEC 61850 and process point treatment according to IEC 60870-5-10x standards. The overall system was based on a modern Linux kernel which allows greater flexibility for continuous improvement, especially in terms of IT security.

The main system comprises:

- LTE wireless mobile modem 4G/3G/2G
- 2 Ethernet LAN TCP/IP connections
- 2 EIA/RS-485 field interfaces
- CL/S0 meter interface with
 - FW-5-GATE-4G cl
 - FW-5-GATE-4G-2D cl
 (reduces the number of RS-485 field interfaces)
- EIA/RS-232/V.24 interface
- Temperature sensor, -25° to +100° C

The PS-60 module allows floating power supply (24 bis 60 V DC (-15%/+ 20%)), galvanic isolation and redundant implementation.

Software

The parametrisation software setIT provides quick launch and high compatibility with telecontrol systems. Thanks to full configuration of all components of the FW-5-GATE-4G device in setIT, there is no need to integrate or adapt an external modem, which can be time-consuming. Up to 8 VPN tunnels with end-to-end-encryption can be set up from the station. In addition, all available information from the mobile radio module can be used in the setIT diagnostics functions.

The optional Soft-SPS codeIT offers additional flexibility and allows for the implementation of diverse PLC programs as per IEC 61131-3.

The visIT Web-based plant visualisation tool

- allows user interfaces to be created conveniently by importing process variables from setIT
- runs as a runtime in the remote terminal unit, has access to its process data/logged values and can display information relevant for service and operation.
- can be displayed safely on almost all HTML5-enabled terminals, smartphones or tablets.



SAE - solutions in mind

If requested, we can assist you with complete project processing. From selecting the best fitting components to coordinating all project participants to practical integration of systems into existing infrastructures. In all these areas, you can take advantage of our extensive know-how.

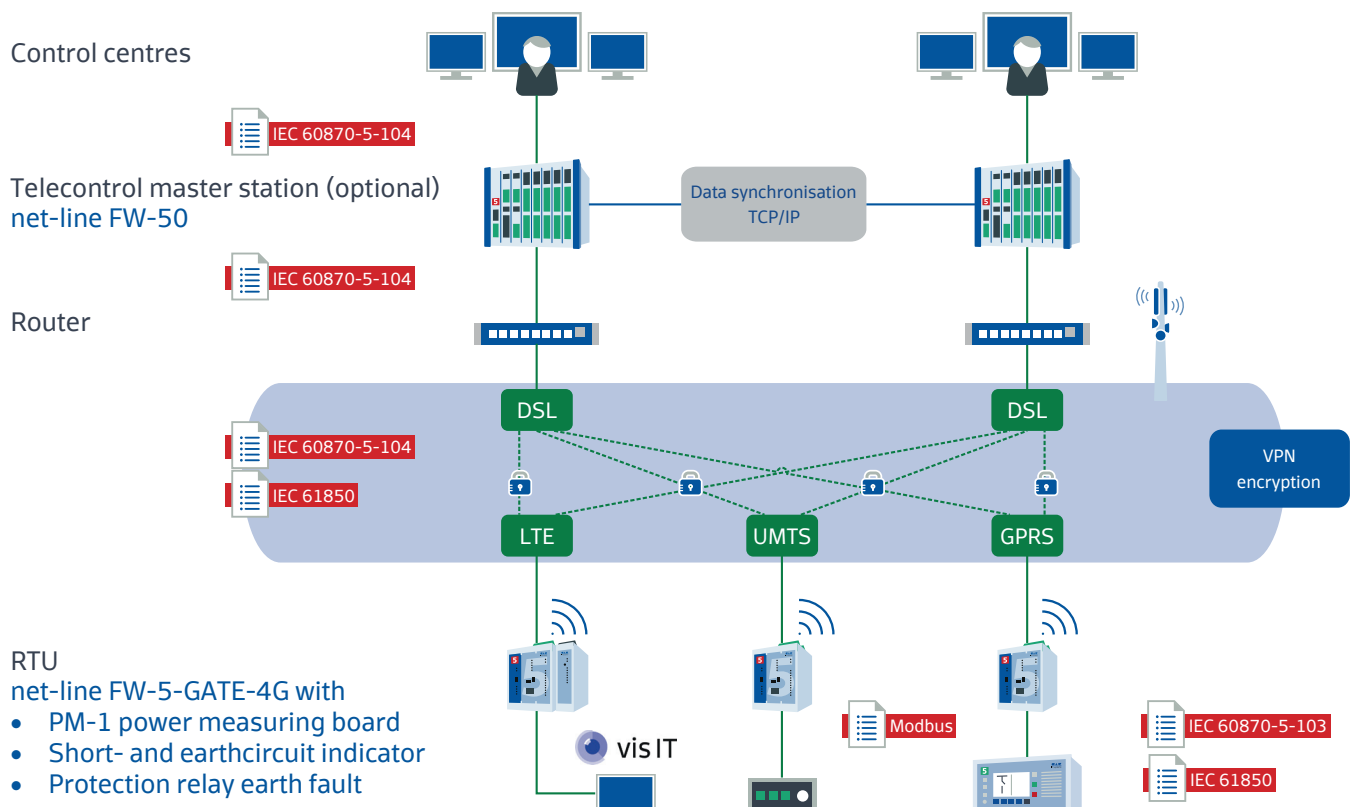

series5e IT security

series5e technology allows for comprehensive IT-Security measures as required in the current requirement profiles of the BDEW whitepaper and BSI recommendations. Security is verified using audits from renown consultants and offices backed up by periodical internal penetration tests.

- Hardened modern kernel
- Extended firewall rules with granular permissions controls
- Denial of Service identification DDOS
- Active ports are restricted to application choice
- https/ftps for protected web servers and remote access
- End-to-end encryption through
 - IPSec (IKEv1/IKEv2)
 - OpenVPN
- SYSLOG service
- User administration with free role based assignment
- Signed firmware
- Signed database
- System commands for releasing diagnostics access
- Patch management

LTE mobile radio modules:

The LTE module radio module offers a flexible coupling to the conductor and energy management systems with high availability through its double antenna MIMO transmission (Multiple Input Multiple Output) and 3G/2G network fallback capability. The basis module allows 3GPP cat3 communication up to 100 Mbit/s. A module is offered as an option with 3GPP cat1 with 10 Mbit/s, DUAL-SIM and GPS time synchronisation.

FW-5-GATE-4G	Default mobile router LTE module 3GPP rel8, cat3; Europe EMEA
Transmission	LTE 100 Mbit/s down, 50 Mbit/s up HSPA+ 42 Mbit/s down, 5.76 Mbit/s up, WCDMA 384 kbit/s; EDGE 236.8 kbit/s, GPRS 85.6 kbit/s
Bands	4G: FDD B1/B2/B3/B5/B7/B8/B20 3G: B1/B2/B5/B8 HSPA+ /WCDMA 2G: 850/900/1800/1900 MHz
Antenna	MIMO DL, LTE & HSPA, SMA-f
FW-5-GATE-4G-2D	mobile router LTE-IoT, DUAL-SIM & GPS LTE-IoT module 3GPP rel11, cat1, Europe, Asia
Transmission	LTE 10 Mbit/s down, 5 Mbit/s up HSPA+ 42 Mbit/s down, 5.76 Mbit/s up, WCDMA 384 kbit/s, DGE 236.8 kbit/s, GPRS 85.6 kbit/s
Bands	4G FDD LTE: B1/B3/B5/B7/B8/B20 3G WCDMA: B1/B5/B8 2G GSM: B3/B8 900/1800 MHz
Antenna other	MIMO DL, SMA-f DUAL-SIM DSSS, GNSS: GPS/Glonass/Galileo, clock synchronisation
FW-5-GATE-450	mobile router for 450 MHz CDMA networks CDMA450 CDMA 1xEV-DORevB (ISF-856-A) & 1xRTT, Europe
Transmission	2.4 Mbit/s download, 0.15 Mbit/s upload
Bands	CDMA 450 MHz B31
Antenna	diversity, SMA-f

Extension modules

The net-line FW-5-GATE-4G can be flexibly expanded with up to 12 extension modules (EM) and as required via an internal bus system. If the power supply to the basis station is not sufficient, the current booster PWR-1 can provide an additional 2.8 A. The TBUS expansion allows distributed EMs to be integrated as a remote I/O. Like the base unit, all the modules except for PM-1 are equipped with screw or spring terminals.



* up to 12 modules with TBUS-R or current booster PWR-1

8DI/8DI-220	8 messages $\pm 18 \dots \pm 72$ V DC/ $\pm 110/\pm 220$ V DC, as per root
8DO/8DO-220	8 relays no. 72 V DC/220 V DC, 230 V AC, 2-pole, isolated
4AI	4 measured values 16 bit, $\pm 2.5 / \pm 5 / \pm 10 / \pm 20$ mA, 2-pole
2AO	2 set point commands 16 bit ± 20 mA, 2-pole
4AO	4 set point commands 16 bit ± 20 mA, 2-pole
8DI2AI/8DI2AI-220	8 messages $\pm 18 \dots \pm 72/\pm 110/\pm 220$ V DC, as per root 2 measured values 16 bit, $\pm 2.5 / \pm 5 / \pm 10 / \pm 20$ mA, 2-pole
4DI4DO-1	4 messages $\pm 18 \dots \pm 72$ V DC, 2-pole, isolated 4 commands co monostable 75 V DC, 2 A up to 48 V DC
4DI4DO-2	4 messages $\pm 18 \dots \pm 72$ V DC, 2-pole, isolated 4 commands co bistable, 75 V DC, 2 A up to 48 V DC
DSO-1	6 commands 72 V DC 1.5-pole 1/n, measuring circuit test 6 return information 18 ... 72 V DC
DSO-2	2 commands 72 V DC 2-pole 1/n, measuring circuit test 2 return information 18 ... 72 V DC
RES-1	4 SO inputs message/counter vales 2 measured values 16 bit, $\pm 2.5 / \pm 5 / \pm 10 / \pm 20$ mA, 2-pole 4 relays no 72 V DC, 2-pole, isolated
PM-1	Power measurement terminal for LV- and MS networks Measurement via converter, Rogowski coil or sensors
PM-1	Power measurement terminal for LV- and MS networks Measurement via converter, Rogowski coil or sensors
PDPS-1	Profibus-DP Slave
PS-60	Wide range power supply 24 to 60 V DC
PWR-1	Additional power supply, 2,9 A
IFX-485-1	RS-485 converter (V.24 to RS-485)
VPP-1	6 messages 24 to 60 V D 5 commands to 60 V DC 2 measured values ± 20 mA, individual channel floating

Technical data: net-line FW-5-GATE-4G

Structure	Station control, telecontrol and automation system in plastic housing, can be expanded with I/O and communication modules for top-hat rail mounting
Communication	LTE modem 4G, fallback to 3G/2G, MIMO, opt. DUAL-SIM 2 Ethernet LAN TCP/IP, 10/100BaseTx, auto-MDIX, auto-negotiation 1 RS-485 interface, galvanically isolated 1 RS-485 counter interface or CL/S0 interface, galvanically isolated 1 RS-232/V.24 interface
Inputs/outputs	Up to 12 expansion modules for operation of single-/double-point, transformer tap and alarm signals, measurands, metered values, single, double and transformer tap commands, temperature sensor for ambient temperature, -25 °C to 100 °C, measuring error ±3°C max.
Protocols	IEC 61850 · IED and protection device coupling IEC 60870-5-101 · telecontrol technology, station control technology IEC 60870-5-103 · protection device coupling IEC 60870-5-104 · TCP/IP coupling to control centre DNP3 server · serial/IP IEC 62056-21 · meter connection (IEC 1107) SML smart meter connection via Ethernet DSfG · Digital interface for gas measuring devices Modbus RTU/TCP · master/slave, Profibus-DP slave, MPI/3964R/RK512 · field bus SNMPv3 · Network management NTP-/SNTP-/DCF clock synchronisation VPN tunnel · IPsec (IKEv1/IKEv2), OpenVPN Syslog-ng Server, LDAP- and RADIUS-Server
PLC programming	IEC 61131-3 compatible via codeIT, 128 kb program memory
CPU series 5e	RISC processor Cortex-A8, 1200MIPS@800 MHz, FPU, Watchdog, RTC 1 GB RAM (512 MB SDRAM, 512 MB SLC Flash), 8 MB NOR Flash
Memory extension	1 GB microSD card (up to 8 GB in perspective)
Real time clock	Errors max. ±10 ppm in operation, maintenance-free buffer ±20 ppm 60 days @25°C, daylight saving time changeover, leap year correction
Status displays	Process status of the PLC, LED in front panel for system, communication, VPN and mobile status, diagnostics via integrated web server, optional: visIT plant visualisation
Service interface	Ethernet LAN 10/100BaseTx, auto-MDIX, USB 2.0 device 480 Mbit/s, USB 2.0 host 480 Mbit/s (configuration/archive synchronisation via stick)
Fault signal output	To be configured to relay output, configurable sys-LED
Power supply	24 bis 60 V DC (-15% + 20%), no galvanic isolation, power failure management with power failure buffering With additional expansion module PS-60: 24 V DC to 60 V DC (-15%/+20%), insulation 1500 V
Dielectric strength	5 kV surge, supply and process I/O for PE, according to class VW3 2.5 kV surge, supply to RS-232, USB
Standards	EMC: IEC 61000-6-2, IEC 61000-6-3, Device class B ETSI EN 301 489-1, 7, 24, Radio: ETSI EN 301 511, ETSI 301 908-1, 2, 13 Security: DIN EN 62368-1, EN 62311, EN Insulation: IEC 60870-2-1, IEC 60255-5
Housing	Polyamide V0, IP20, weight 310 g Dimensions: 68×105×115 mm (W×H×D), Expansion modules: 22.5×105×115 mm (W×H×D)
Installation	DIN top-hat rail, DIN-EN 60715 TH35
Terminals:	MSTB removable screw-type or spring terminal Combicon, 0.2 to 2.5 mm²
Environment	-25° to +70°C, ø24h max. +55° C, max. 3000 m above sea level, humidity < 95%, without condensation

Product variants

FW-5-GATE-4G

RTU with 4G mobile radio modem 2 LAN interfaces, separated
2 RS-485 field- & meter connection 1 RS-232/V.24 interface

FW-5-GATE-4G CL

RTU with 4 mobile radio modems 2 LAN interfaces, 1 RS-485 field interface, 1 CL/S0 meter pulse interface, 1 RS-232/V.24 interface

FW-5-GATE-4G-2D

as with FW-5-GATE-4G,
4G module cat 1, LTE IoT, DUAL-SIM, GPS
Position and clock sync.

FW-5-GATE-4G-2D CL

as with FW-5-GATE-4G CL,
4G module cat 1, LTE IoT, DUAL-SIM, GPS
position and clock Sync.



Member of LACROIX Group

SAE IT-systems GmbH & Co. KG
Im Gewerbegebiet Pesch 14
50767 Cologne, Germany
Tel.: +49(0)221/59 808-0
Fax: +49(0)221/59 808-60
info@sae-it.de
www.sae-it.com