

USER GUIDE

Megger®

HVcompact

High voltage measurement system



Register →
megger.com/register



Support →
megger.com/support



EN
ENGLISH

This document is copyright of:

Megger ■ Power Diagnostix Instruments GmbH, Vaalser Strasse 250, 52066 Aachen, GERMANY
T +49 (0)241 749271 F +49 (0)241 79521 www.megger.com

Megger reserves the right to alter the specification of its products from time to time without notice. Although every effort is made to ensure the accuracy of the information contained within this document it is not warranted or represented by Megger to be a complete and up-to-date description.

This manual supersedes all previous issues of this manual.
Please ensure that you are using the most recent issue of this document.
Destroy any copies that are of an older issue.

Declaration of Conformity

Hereby, Megger declares that equipment manufactured by Power Diagnostix Instruments GmbH described in this user guide is in compliance with Directives 2014/30/EU, 2014/35/EU, and 2011/65/EU. Other equipment manufactured by Power Diagnostix Instruments GmbH described in this user guide is in compliance with Directive 2014/53/EU where it applies.

Contents

1. Introduction	5
1.1 About this user guide	5
2. Instrument safety	6
2.1 Warnings, Cautions, and Notes	6
2.2 Safety, Hazard, and Warning symbols on the instrument	7
3. General information	8
4. Installation	9
5. Menus	11
5.1 Main menu	11
5.1.1 Scope display ("MAIN S" menu)	11
5.1.2 Meter display ("MAIN M" menu)	11
5.2 Scale menu = Scaling of the meter	12
5.3 Result menu = Measurement history	12
5.4 Setup menu	13
5.5 Reset to default settings	15
6. Miscellaneous	16
6.1 Maintenance	16
6.2 Product marks	16
6.3 Shipment instructions	16
6.4 Declaration of conformity	17
6.5 UK declaration of conformity	17
7. Technical data	18
7.1 Optional features	18

1. Introduction

1.1 About this user guide

This manual describes the hardware, software, and usage of the HVcompact in its current version.

Some of the hardware features of the most recent versions are not available with earlier versions of the instrument. It is possible to upgrade most of the previous instruments to the features of the current instruments. Contact Megger for information regarding upgrade possibilities or accessories for the instrument via the contact form on the Megger web site (www.megger.com).

2. Instrument safety

These safety warnings must be read and understood before the instrument is used. Retain for future reference.

2.1 Warnings, Cautions, and Notes

Only qualified and trained operators should operate the ICMobserver. Each operator must read and understand the following safety information and this user guide prior to operating the equipment. The safety precautions herein are not intended to replace the safety procedures of your company.

In particular, read and follow the information marked with the words **WARNING** and **CAUTION**. The word **WARNING** is reserved for conditions and actions that pose hazards to the user, while the word **CAUTION** is reserved for conditions and actions that may damage the instrument or its accessories, or that may lead to malfunction.

This user guide follows the internationally recognised definition. These instructions must be adhered to at all times.

Description
WARNING : Indicates a potentially dangerous situation which, if ignored, could lead to death, serious injury or health problems.
CAUTION : Indicates a situation which could lead to damage of the equipment or environment
NOTE : Indicates important instructions to be followed to perform the relevant process safely and efficiently.





Always obey the safety rules given with the warnings and in this section. Make sure to take care of the safety issues while performing field measurements. Never disregard safety considerations even under the time constraints frequently encountered during on-line and off-line tests on site.

WARNING:

- Always provide solid grounding of the instrument and the coupling units. Never operate the instrument without protective grounding.
- Use isolation techniques, such as isolation transformers or fibre optic isolation to avoid hazard and injury. With applications bearing a high risk of electrical shock or breakdown use fibre optic isolation in general.
- Avoid working alone.
- Do not allow the instrument to be used if it is damaged or its safety is impaired.
- Inspect the ground leads and signal cables for continuity.
- Select the proper coupling circuit and connection for your application.
- Do not use the instrument in an environment that is at risk of explosion.

2.2 Safety, Hazard, and Warning symbols on the instrument

This paragraph details the various safety and hazard icons on the instrument's outer case.

Icon	Description
	Warning: High Voltage, risk of electric shock
	Caution: Refer to user guide.
	EU conformity. Equipment complies with current EU directives.
	UK conformity. This equipment complies with current UK legislation
	Do not dispose of in the normal waste stream.

3. General information

The HVcompact is a high voltage (HV) meter with an auto-ranging oscilloscope and meter display of the voltage. The unit further displays U_{DC} , U_{RMS} , \hat{U} , $\hat{U}/\sqrt{2}$, the measurement frequency, and the crest factor. To improve the readability, one of four measurement values is displayed using large characters. For the protection of test specimens, the unit offers a adjustable voltage limit, which trips a relay output if the limit is exceeded. The divider ratio is freely adjustable and is kept in a non-volatile memory.

The HVcompact comes either in a 19-inch housing, which can be placed in a 19-inch rack, or in a half 19-inch desktop housing that allows tabletop operation. In case of a 19-inch desktop housing, the integrated feet of the instrument must be folded out to provide proper ventilation of the HVcompact. Five buttons are arranged to the right-hand side of the backlit liquid crystal display (LCD) for the control of the instrument. The brightness control of the LCD is located beneath these buttons. A small screwdriver is needed to access the brightness control. The instrument automatically compensates for changes of the brightness due to changing of the ambient temperature.

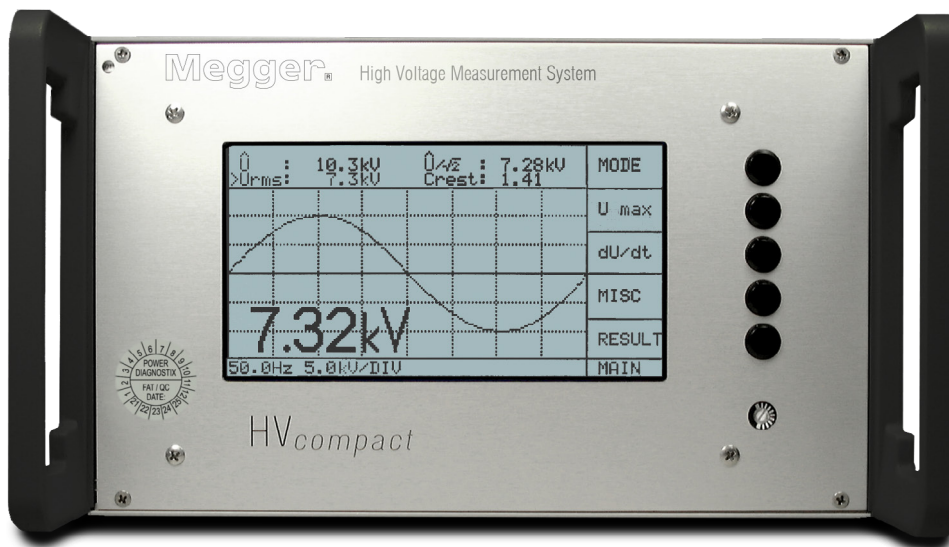

Figure 1: HVcompact in a half 19-inch desktop housing

4. Installation

Before using the HVcompact, the following wiring must be done:

- Mains power supply (adjusts automatically between 100 V and 240 V AC)
- Voltage signal of an HV divider connected via coaxial cable (RG58) to the "U in" BNC jack (max. 200 V_{peak})
- If required, interconnection of the relay output with the test set control (see Figure 4)
- If required, connection of a paper recorder to the "REC" output
- Solid system grounding using the wing nut terminal

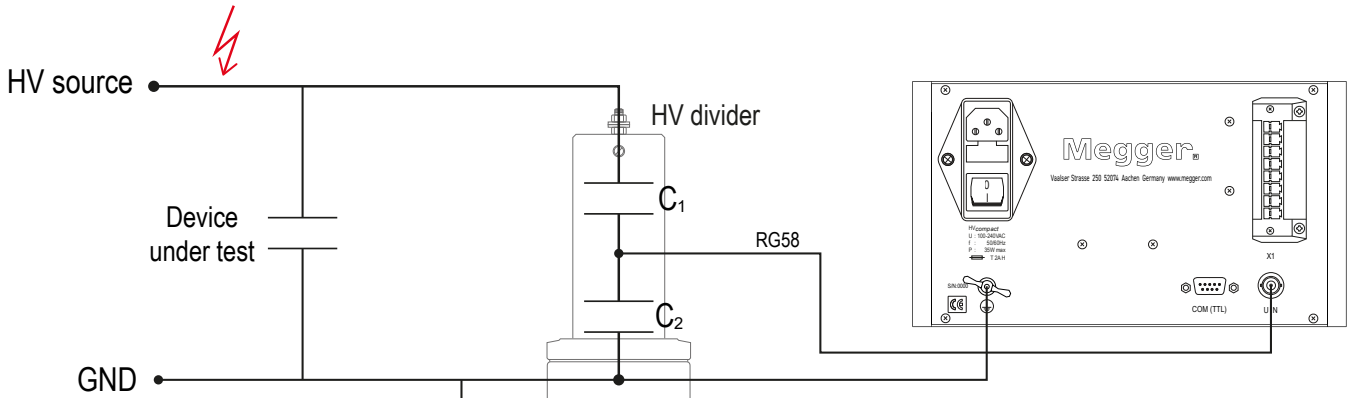

Figure 2: Connection principle

Installation

The rear panel of the HVcompact carries the power supply socket including the mains switch, the connector for the relay output and the recorder output (REC), the wing nut terminal for ground connection, the serial connector "COM TTL" and the BNC connector for the voltage signal input ("V in").

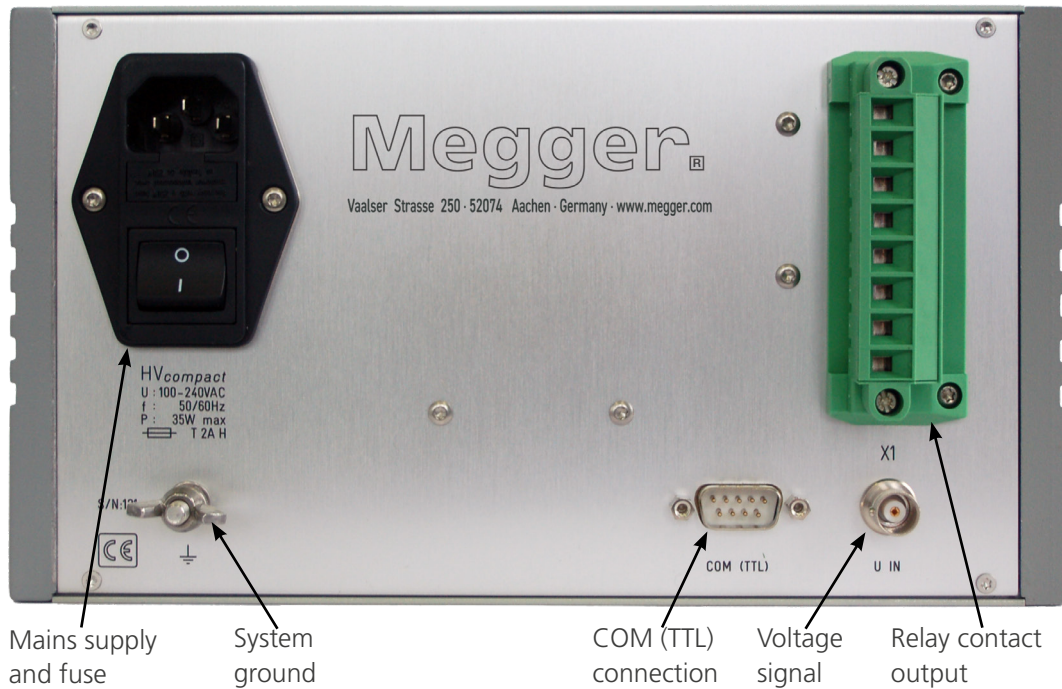

Figure 3: Rear panel of the HVcompact

The relay contact output is connected via an 8-pin plug component (PC4/8ST-7,62). The pin connection for this plug is shown in Figure 4.

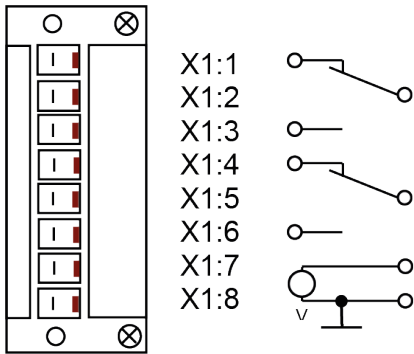

Figure 4: Connections of the 8-pin connector

5. Menu

5.1 Main menu

Directly after powering up, the unit displays the HVcompact logo. Subsequently, the instrument selects the display of the last selected MAIN menu. The display mode can be changed by METER and SCOPE.

5.1.1 Scope display ("MAIN S" menu)

Provided, the input voltage signal is big enough ($> \sim 0.5 \text{ V}$) and the frequency is found between 20 Hz and 510 Hz (20 Hz and 300 Hz with older versions), the voltage waveform is displayed in a way that one cycle can be seen. The voltage curve is scaled automatically, if the signal reaches 10 % of its nominal value ($\sim 10 \text{ V}$). The scaling factor of the graticule can be found in the lower line next to the synchronisation frequency.

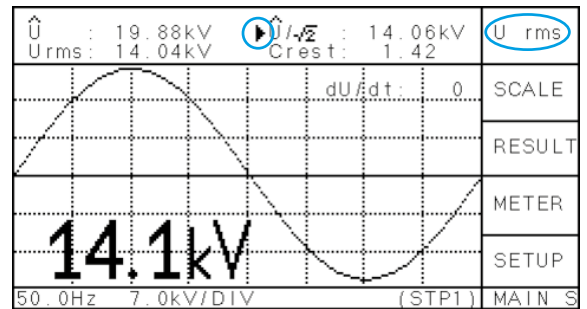

Figure 5: Main menu in SCOPE mode

5.1.2 Meter display ("MAIN M" menu)

By default, the scaling of the METER display is done automatically according to the input voltage and the set divider factor. In the menu SCALE, the scaling of the METER display can be changed manually. This setting will be stored until the automatic mode is selected ('>AUTO').

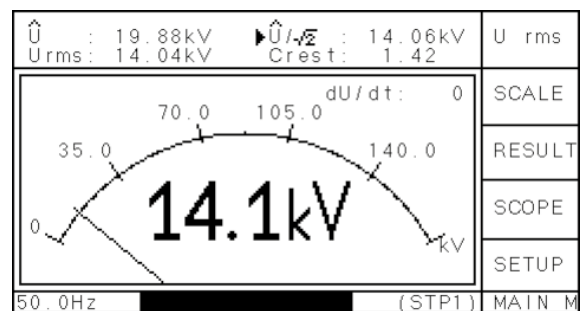

Figure 6: Main menu in METER mode

From the acquired waveform, the instrument calculates the peak voltage (\hat{U}), the effective voltage (U RMS), the peak voltage divided by the square root of two ($\hat{U}/\sqrt{2}$), the crest factor ($\hat{U}/U \text{ RMS}$) and, if "U DC" is selected, the mean voltage. The period to calculate the mean value of "U DC" is taken from the synchronisation frequency, which is shown in the lower left corner of the display (usually 50 or 60 Hz).

The top button will select, which of the four values is $U \text{ DC}$ → $\hat{U}/\sqrt{2}$ → $U \text{ rms}$ → \hat{U} shown using large characters. This setting additionally selects, which of the voltage values is recorded in the menu "RESULT" and which value is used for the low voltage discriminator (either $\hat{U}/\sqrt{2}$ or U RMS). The symbol in the upper two display lines indicates, which of the values is selected (see Figure 5). If the DC voltage is selected, the display of the waveform will change accordingly.

5.4 Setup menu

In the "SETUP" menu, parameter can be set to adapt the instrument to a specific test configuration. If the HVcompact is used at different locations or with different voltage dividers, up to seven different parameter setups can be saved. The whole setup can be changed and labelled in the menu "SELECT", which is accessible by selecting the top line of the "SETUP" menu.

1 SETUP_NO_1	/ \	⇐ Moves one up, to enter the "SELECT" menu
>DIVIDER RATIO : 2034	< / \	⇐ Moves one down, for changing the max. voltage limit
MAX VOLTAGE LIMIT : 100.0 kV	SET	⇐ Opens the "SET" menu for changing the divider ratio
dU/dt MODE : OFF	INFO	⇐ Opens the menu "INFO"
dU/dt SENSIBILITY : 10 %	EXIT	⇐ Moves back to the main menu
LOW VOLTAGE DISC : 0.20 kV		
RECORDER OUTPUT : 100 kV		
LIGHT TIMER : 30 MIN		
REFRESH MODE : SMOOTH		
KEY TONE (BEEP) : LOW		
KEY LOCK : OPEN		
DEFAULT FREQUENCY : 50 Hz		
50.0Hz	U _{rms} = 2.808kV	SETUP1

Figure 12: Setup menu

Within the menu "SELECT", the button "LOAD" activates the selected setup. The name of the activated setup is shown in the bottom line.

The button "LABEL" will switch to the menu EDIT, where the setup name (label) can be changed. Valid characters for the label are the ten digits, the underscore, and all capital letters. The changed value/character is saved immediately without confirmation.

Within the menu "SETUP", single parameters of the active setup can be changed. The button "SET" leads to a submenu, where the single digits of the value can be modified. The menu "INFO" shows details about the hard- and software version of the instrument, as well as contact details of Power Diagnostix.

DIVIDER RATIO

The divider ratio of the HV voltage divider has to be inserted as a factor of 1:x. E.g., with a divider factor of 1000, a maximum measuring range of 140 kV is possible when the maximum voltage input is: $V_{in\ max.} = 140 V_{eff}$

The calculated voltage is shown in the bottom line on the right-hand side. After pressing the "SET" button, the value can be increased ('^') or decreased ('v') digit by digit until the voltage equals a known voltage value, given by, e.g., sphere gap calibration or a temporarily installed meter.

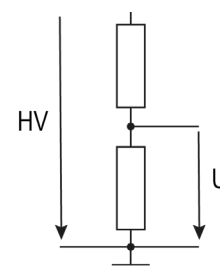

MAX VOLTAGE LIMIT

A maximum voltage level for $\hat{U}/\sqrt{2}$ or U DC can be set to trigger the relay switch U_{max} on the rear panel. If the voltage $\hat{U}/\sqrt{2}$ or U DC exceeds the set limit, the contact between X1:5 and X1:6 is closed (see Figure 4).

dU/dt MODE (only firmware versions > 1.20)

The dU/dt mode defines the action taken after a breakdown has occurred. With "OFF" selected, nothing will be done. With "COUNTER" selected, the number of breakdowns is displayed. This number can be set to zero by "RESULT" and "CLEAR". With "RELAY" selected, a breakdown will switch the dU/dt relay (see Figure 4).

dU/dt SENSITIVITY (only firmware versions > 2.0)

The different settings are "VERY LOW", "LOW", "MEDIUM", "HIGH" and "VERY HIGH". The voltage values of two successive cycles are compared. The maximum deviation in percent of the maximum voltage is compared with a predefined value, depending on this setting. The setting "VERY LOW" allows a higher deviation than "VERY HIGH". If this deviation exceeds the limit and the "RELAY" mode is selected, the relay contact X1:1 – X1:2 is opened (see Figure 4).

dU/dt LIMIT (firmware versions > 1.19)

In this setting, a maximum voltage change per time [kV/ms] can be set to detect single voltage dips. In case a single breakdown or flashover occurs and the dU/dt value is exceeded, the relay contact X1:1 – X1:2 is opened (see Figure 4).

The minimum dU/dt value must be larger than the maximum rise time of the waveform. With sine waves this is at 0°. Since one whole cycle is sampled with 100 values, the dwell time will be 1/(f·100). With the firmware version 1.20 and greater, the voltage values of two following samples are compared. With dU being calculated by $\hat{U} \cdot \sin(3.6^\circ)$ the minimum setting can be calculated by: $\frac{dU}{dt} \text{ min} = \frac{8.88}{1000} \cdot f \cdot \frac{\hat{U}}{\sqrt{2}}$

As rough approximation, the set value can be calculated by: $\frac{dU}{dt} \text{ min} = \frac{f \cdot \hat{U}}{150}$

\hat{U} = current peak voltage => peak of the operating voltage (with firmware version 1.20)

\hat{U} = full scale voltage => 200 V_{peak} * divider ratio (with firmware version 1.21)

With firmware version 1.21, the dU/dt value is automatically adjusted to the current voltage value.

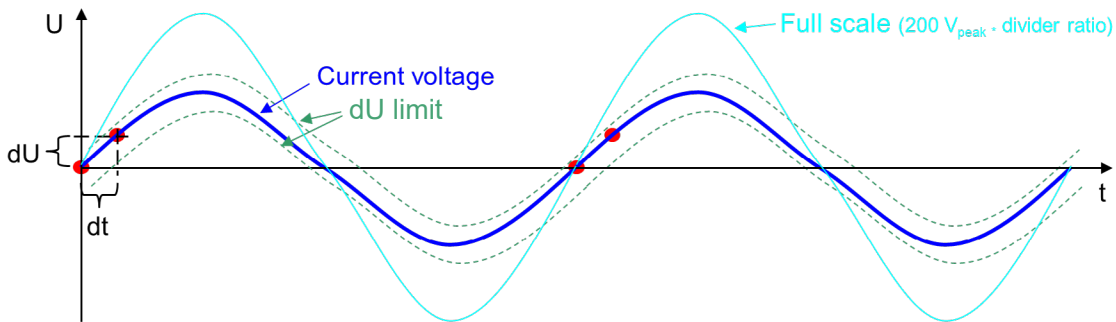

Figure 9: dU/dt value with firmware version 1.21 and higher

You should add 10 % to this value, depending on the input level and the overall noise to avoid an unwanted tripping. Strong harmonics will influence the natural waveform, and therefore the dU/dt value has to be adapted.

dU/dt LIMIT (only firmware versions < 1.19)

With firmware versions < 1.19, the peak voltage of two successive cycles is compared. Therefore, the theoretical minimum dU/dt value is zero. However, instabilities and manual voltage changes require a minimum dU/dt value.

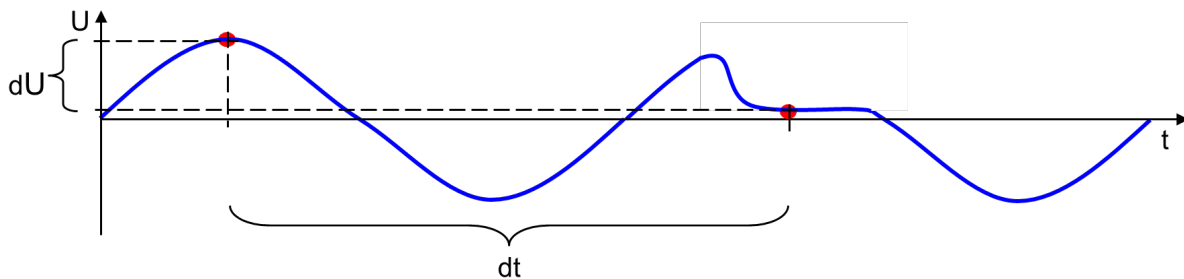

Figure 10: dU/dt value with firmware version up to 1.19

RESULT

If the dU/dt mode is "RELAY" and a voltage dip is recognised, the instrument changes to the "RESULT" menu. Within this menu, the cursor indicates the occurrence of the breakdown. The voltage level just before the breakdown is indicated in the bottom line, whereas the actual voltage is shown in the top line. Pressing any active button exits this display and resumes the recording of voltage values in the "RESULT" menu.

LOW VOLTAGE DISC

If the calculated voltage (either U_{RMS} , $\hat{U}/\sqrt{2}$, or U_{DC} , depending on the selection) is below this level, all voltage values are set to 0 V.

RECORDER OUTPUT

The recorder output terminal (x1:7 and x1:8, see Figure 4) may optionally be connected to a paper recorder or other device to provide a graph of the voltage magnitude. The voltage output gives 0 to 10 V DC and corresponds linearly to the displayed (selected) voltage. If, e.g., the "REC" level is set to 100 kV and the display shows 65 kV, the voltage output equals 6.5 V. The REC output value is altered together with the selection of the displayed voltage.

LIGHT TIMER for the LCD

The back light of the LC display is turned off automatically when no button is pressed. The time delay can be set to a value from 1 to 60 minutes. A shorter time helps saving lifetime of the LCD.

REFRESH MODE

The shown peak values are calculated by up to ten measurements if the voltage level is stable. This smoothing of the values increases the accuracy and should be turned on if possible. However, if a fast display of the values is required, this mode can be turned off.

KEY TONE (BEEP)

In this menu the sound when pushing a button can be changed or turned off.

KEY LOCK

The menu "KEYB" allows locking the keyboard ("LOCK"), leaving only functions available that will not affect the integrity of the measurement. Selecting one of the locked menus:

"U max", "DIV", "LVD", "dU/dt", "RECOU", "SCALE"

will lead to the "KEYB" menu. To unlock the keyboard, the digit sequence **2321** must be entered.

DEFAULT FREQUENCY (only firmware versions > 2.0)

If there is no voltage at the input of the HVcompact, the default frequency is displayed with an asterisk in front. 50 Hz and 60 Hz are selectable.

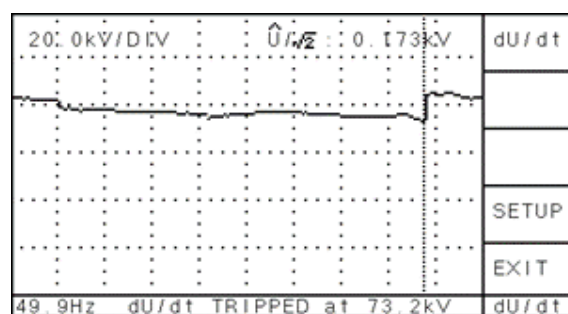

Figure 11: Setup menu

5.5 Reset to default settings

To restore the factory default settings of an HVcompact, press the top and bottom buttons of the button line at the right-hand side simultaneously when switching on the device.

6. Miscellaneous

6.1 Maintenance

The *HVcompact* should be calibrated annually to ensure that its output signal remains within the recommended limits. Besides that, the *HVcompact* does not require any maintenance on a regular basis.

6.2 Product marks

This symbol indicates that the marked product should not be disposed of as normal household waste. As it is a B2B product, it may also not be disposed of at civic disposal centres. If you wish to dispose of this product, do so properly by taking it to an organisation specialising in the disposal of old electrical equipment near you.

Any batteries installed must be disposed of separately from the unit.

As a responsible manufacturer, certified according to ISO 14001, Power Diagnostix offers to take back old instruments from its customers. Contact Megger via the contact form on the Megger web site to discuss the procedure for this.



6.3 Shipment instructions

In case a unit needs to be returned to the factory, make sure the acquisition unit is packed safely. As the units are relatively small, shipment by couriers, such as DHL, FedEx, or equivalent is the recommended mode of transportation. If possible, declare the instrument as 'used instruments for evaluation' at a relative low value. Consult Megger for further details. Megger may provide you with a temporary replacement unit in urgent cases.

6.4 Declaration of conformity

The manufacturer
Power Diagnostix Instruments GmbH
Vaalser Strasse 250
52074 Aachen
Germany

declares, that the product

HVcompact
Digital high voltage measurement system

provided it is installed, maintained, and operated for the its intended use, in accordance with relevant installation standards and manufacturer's instruction, meets the requirements of the following directive(s):

Low Voltage Directive 2014/35/EU
EMC Directive 2014/30/EU
RoHS Directive 2011/65/EU

It complies with the following standards and/or normative documents:

EN 61010-1:2010
EN 61326-1:2013
EN IEC 63000:2018

6.5 UK declaration of conformity

The UK government has laid legislation to continue recognition of current EU requirements, including the CE marking (Conformité Européene, or European Conformity marking). The legislation will apply indefinitely for a range of product regulations. This means businesses will have the flexibility to use either the UKCA (UK Conformity Assessed) or CE marking to sell products in Great Britain (GB). The message text can be found here: <https://www.gov.uk/guidance/using-the-ukca-marking>. Megger sells the GISmonitor Portable in Great Britain using the CE marking. environments and/or additional filter techniques.



7. Technical data

Specification	Detail
Mains supply	100–240 V AC, 50–60 Hz (automatic)
Line fuse  :	1.6 A time-lag
Power requirements	Approx. 20 VA
Display	Backlit LCD
Display resolution	128 x 240 pixels B/W
Operation	5 menu supported buttons
Input	100 V RMS or ± 200 Vpeak
Input impedance (PD)	50 Ohm 50 pF
Frequency range	20–300 Hz (> firmware version 1.03) 20–510 Hz (> ver. 1.14)
Precision	<0.5 % +0.5 V
A/D converter	± 11 bit
Samples	197 samples per cycle, e.g., 20 ms @ 50 Hz -> 100 μ s per sample
Operation temperature	0–40 °C (non-condensing)
Recorder output	0–10 V with RO = 100 Ω (BNC connector)
Voltage limit (Umax)	One single-pole, double-throw contact max. ~250 V, 5 A
Break-down limit (dU/dt)	One single-pole, double-throw contact max. ~250 V, 5 A
Overall size	236 x 133 x 300 mm ³ (W x H x D, exclusive connectors)
Weight	Approx. 3.5 kg

7.1 Optional features

Specification	Detail
Serial interface	RS-232, 57.6 kB
LAN interface	RJ-45

Megger

Power Diagnostix Systems GmbH

Vaalser Strasse 250

52074 Aachen

Germany

Telephone +49 241 74927

Fax +49 241 79521

This instrument is manufactured in Germany.

The company reserves the right to change the specification or design without prior notice.

Megger is a registered trademark

www.megger.com

HVcompact_UG_e1.01

The word 'Megger' is a registered trademark. Copyright © 2025

Megger ^R